

ITEM NO. \_\_\_\_\_  
 PROJECT \_\_\_\_\_  
 LOCATION \_\_\_\_\_  
 DATE \_\_\_\_\_ QTY. \_\_\_\_\_



MCATS-122S

*Features the lowest entry point in the industry allowing easier access for small children*



# MCATS SERIES

## Air-Thru Open Front Milk Coolers

### STAINLESS INTERIOR & EXTERIOR MODELS

- MCATS-082S
- MCATS-122S
- MCATS-162S

### OPTIONAL WHITE INTERIOR & EXTERIOR MODELS

- MCATS-082W
- MCATS-122W
- MCATS-162W

## FEATURES

### CONSTRUCTION

- Exterior of doors and remaining exterior is stainless steel. Remaining exterior also available in white enamel over smooth steel.
- Interior of doors and remaining interior is stainless steel. Remaining exterior also available in white enamel over smooth steel.
- Cabinet is insulated with foamed-in-place polyurethane
- Four easy roll swivel casters, two locking
- Epoxy-coated heavy-duty floor racks

- NSF-listed drain
- NSF-listed thermometer

### DOOR

- Door is insulated and has gaskets
- Chrome-plated hinges
- Key locks
- Fold-back door locks to safely stay open during use

### REFRIGERATION

- Air-thru evaporator
- Self-contained design
- Refrigerant: R-134a
- Easily accessed modular refrigeration system flush

mounted on side of cooler with all components outside the milk storage compartment

- Large cooling capacity to maintain the required storage temperature
- Condensate evaporator
- Operating temperature: 38°F (3°C)

### WARRANTY

- Standard limited one year compressor, 18 month labor and one year limited parts

## CAPACITY

MODEL	CASES WITH CARTONS				LOOSE CARTON (WITHOUT CASES)	
	13" x 13" x 11"H		19" x 13" x 11"H		1/2 PINT	1 PINT
	CASES	CARTONS	CASES	CARTONS		
MCATS-082S	8	352	4	288	864	432
MCATS-122S	12	528	8	576	1368	684
MCATS-162S	16	704	12	864	1800	900

## OPTIONS

- White interior and exterior
- Extended four year compressor warranty



21720 South Wilmington Ave. • Suite 309 • Long Beach, CA 90810  
 P: 888-478-8600 • F: 310-513-8156 • www.koolstar.com

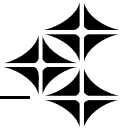

# Kool Star

## MCATS SERIES AIR-THRU OPEN FRONT MILK COOLERS

### TECHNICAL SPECIFICATIONS

MODEL	DIMENSIONS (in.)			DIMENSIONS (mm)			VOLTS	AMPS	UNIT H.P.	NO. OF FLOOR RACKS	CAP. CU. FT.	SHIP CU. FT.	SHIP WT. (LB/KG)
	L	D	H*	L	D	H*							
MCATS-082S	47	33 <sup>1</sup> / <sub>8</sub>	37	1194	845	940	115	4.4	1/5	2	13.0	43.3	250/114
MCATS-122S	61	33 <sup>1</sup> / <sub>8</sub>	37	1549	845	940	115	5.5	1/4	3	19.9	55.1	300/136
MCATS-162S	75	33 <sup>1</sup> / <sub>8</sub>	37	1905	845	940	115	5.5	1/4	4	25.6	67.1	350/159

\*Height includes casters.

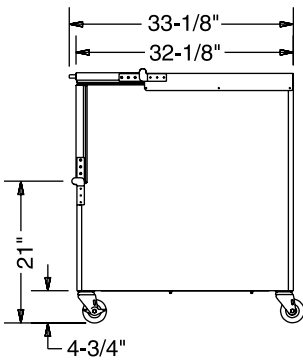

SIDE VIEW - ALL

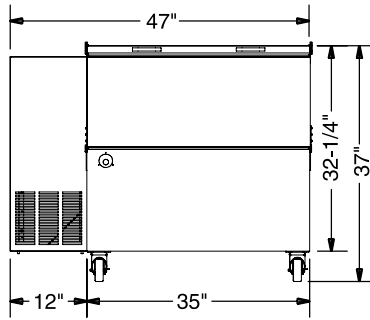

MCATS-082S ELEVATION VIEW

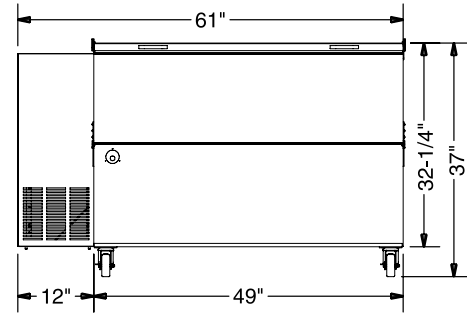

MCATS-122S ELEVATION VIEW

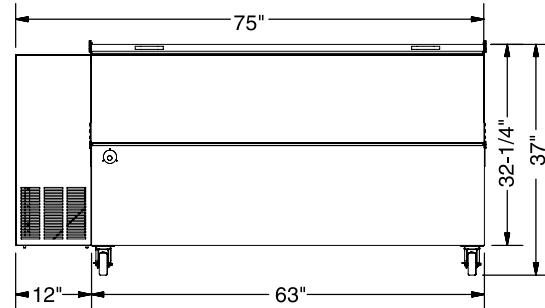

MCATS-162S ELEVATION VIEW

### LISTINGS



### HOOKUP

Via plug in, 8 foot long flexible three wire 16/3 cord with molded plug.

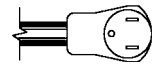

NEMA 5-15P

### BID SPECIFICATIONS

Item no. MCATS \_\_\_\_\_  
Provide \_\_\_\_\_ ( ) Air-Thru Open Front Milk Cooler(s), Kool Star model no. MCATS \_\_\_\_\_.

Milk cooler to be constructed of stainless steel on interior and exterior of doors and remaining cabinet. Remaining cabinet will also be available in optional white painted steel. Cooler will be insulated with foamed-in-place polyurethane and will be equipped with four swivel casters,

two of which will be locking. Epoxy-coated heavy-duty floor racks will also be standard as will an NSF-listed drain and thermometer.

Door to be insulated and will have gaskets and chrome-plated hinges. In addition, doors will fold back and lock to safely stay open during use and will feature key locks.

The refrigeration system will feature an exclusive air-thru, self-contained design and will have a condensate evaporator. The system will be a modular type flush mount-

ed on side of cooler with all components outside the milk storage compartment. The refrigerant will be R-134a and the operating temperature will be 38°F (3°C).

Cooler to have standard limited one year compressor, 18 month labor and one year limited parts warranty.

Cooler to be UL and C-UL listed, UL EPH classified as well as Energy Star and California Energy Code certified.

NOTE: Cabinet designed for optimum performance in air-conditioned area at 75°F ambient and 55% relative humidity. All specifications subject to change without notice.



21720 South Wilmington Ave. • Suite 309 • Long Beach, CA 90810  
P: 888-478-8600 • F: 310-513-8156 • www.koolstar.com



1316-7/08-1.5m  
©Kool Star division of Standex International, Inc. All rights reserved. Printed in U.S.A.